

Test Report

Report No. : MTi250815018-0107E1

Date of issue : 2025-10-11

Applicant : Sariana LLC

Product : OntheGo 7-in-1 Multiport Adapter

Model(s) : MN25STI03

Shenzhen Microtest Co., Ltd.



TEST REPORT

Report No.: MTi250815018-0107E1

Table of contents

1	General Description	4
1.1	Description of the EUT	4
1.2	Description of test modes	4
1.3	Environmental Conditions	5
1.4	Description of support units	5
1.5	Measurement uncertainty	5
2	Summary of Test Result	6
3	Test Facilities and accreditations	7
3.1	Test laboratory	7
4	List of test equipment	8
5	Evaluation Results (Evaluation)	10
5.1	Harmonic current emission	10
6	Emission Test Results (EMI)	11
6.1	Conducted emissions from AC mains power ports (150kHz-30MHz)	11
6.2	Asymmetric mode conducted emissions (150kHz-30MHz)	14
6.3	Radiated emissions (30MHz-1GHz)	16
6.4	Voltage fluctuations and flicker	19
7	Immunity Test Results (EMS)	21
7.1	Electrostatic discharges	22
7.2	RF electromagnetic field disturbances	26
7.3	Electrical fast transients / burst for AC mains power ports	28
7.4	Electrical fast transients / burst for analogue/digital data ports	29
7.5	Surges for AC mains power ports	30
7.6	Continuous induced RF disturbances for AC mains power ports (150kHz-80MHz)	31
7.7	Continuous induced RF disturbances for analogue/digital data ports (150kHz-80MHz)	32
7.8	Voltage dips and interruptions	33
	Photographs of the test setup	34
	Photographs of the EUT	40

TEST REPORT

Report No.: MTi250815018-0107E1

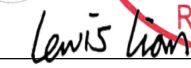
Test Result Certification		
Applicant	Sariana LLC	
Applicant Address	7365 Mission Gorge Rd, Suite G, San Diego, CA 92120, USA	
Manufacturer	Sariana LLC	
Manufacturer Address	7365 Mission Gorge Rd, Suite G, San Diego, CA 92120, USA	
Factory	Sariana LLC	
Factory Address	7365 Mission Gorge Rd, Suite G, San Diego, CA 92120, USA	
Product description		
Product name	OntheGo 7-in-1 Multiport Adapter	
Trademark	S A T E C H I	
Model name	MN25STI03	
Series Model(s)	N/A	
Standards	EN 55032:2015+A1:2020 EN IEC 61000-3-2:2019+ A1:2021 EN 61000-3-3:2013+A2: 2021 EN 55035:2017+A11:2020	
Testing Information		
Date of test	2025-09-17 to 2025-10-11	
Test result	Pass	
Prepared by:	Lyla Cao	
Reviewed by:	David Lee	
Approved by:	Lewis Lian	



TEST REPORT

Report No.: MTi250815018-0107E1

1 General Description

1.1 Description of the EUT

Product name:	OntheGo 7-in-1 Multiport Adapter
Model name:	MN25STI03
Series Model(s):	N/A
Model difference:	N/A
Electrical rating:	Input: DC 5-20V Output: DC 5V/900mA
Accessories:	N/A
Test sample(s) number:	MTi250815018-01-E001

1.2 Description of test modes

No.	Emission test modes
Mode1	Charging(USB-C Female)+USB-C Cable(Conneted PC)+(USB-A Female*2+SD/Micro SD) (data transmission)+HDMI Output+RJ45(LAN)

TEST REPORT

Report No.: MTi250815018-0107E1

1.3 Environmental Conditions

During the measurement the environmental conditions were within the listed ranges:

Temperature:	15°C ~ 35°C
Humidity:	20% RH ~ 75% RH (30% RH ~ 60% RH for ESD test)
Atmospheric pressure:	98 kPa ~ 101 kPa

1.4 Description of support units

The EUT has been tested as an independent unit together with other necessary accessories or support units. The following support units or accessories were used to form a representative test configuration during the tests.

Support equipment list			
Description	Model	Serial No.	Manufacturer
Laptop	/	/	OMEN
AC/DC Adapter (65W)	AD652G		XIAOMI
USB flash disk	64G	/	SAMSUNG
TF card	64G	/	SAMSUNG
Monitor	TPC-AA501	/	Acbel Electronic(Dong Guan)CO., ltd
SD card(64G)	MB-MC64K	KPPF372HB236	SUMSUNG
Laptop	e485	/	Lenovo
Support cable list			
Description	Length (m)	From	To
/	/	/	/

1.5 Measurement uncertainty

Measurement	Uncertainty
Conducted emissions (AMN 150kHz~30MHz)	±3.1dB
Conducted emissions (AAN 150kHz~30MHz)	±4.7dB
Radiated emissions (30MHz~1GHz)	±4.7dB
Temperature	±1 °C
Humidity	± 5 %

This uncertainty represents an expanded uncertainty expressed at approximately the 95% confidence level using a coverage factor of k=2.

TEST REPORT

Report No.: MTi250815018-0107E1

2 Summary of Test Result

No.	Item	Standard	Requirement	Result
1	Conducted emissions from AC mains power ports (150kHz-30MHz)	EN 55032:2015+A1:2020	Class B	Pass
2	Asymmetric mode conducted emissions (150kHz-30MHz)	EN 55032:2015+A1:2020	Class B	Pass
3	Radiated emissions (30MHz-1GHz)	EN 55032:2015+A1:2020	Class B	Pass
4	Harmonic current emission	EN IEC 61000-3-2:2019+A1:2021	Class A	N/A
5	Voltage fluctuations and flicker	EN 61000-3-3:2013+A2:2021	Clause 4	Pass
6	Electrostatic discharges	EN 55035:2017+A11:2020	Contact Discharge: +/- 4kV Air Discharge: +/- 8kV	Pass
7	RF electromagnetic field disturbances	EN 55035:2017+A11:2020	3V/m, 80%, 1kHz Amp. Mod.	Pass
8	Electrical fast transients / burst for AC mains power ports	EN 55035:2017+A11:2020	1kV; 5/50ns Tr/Th; 5kHz Repetition Frequency	Pass
9	Electrical fast transients / burst for analogue/digital data ports	EN 55035:2017+A11:2020	0.5kV; 5/50ns Tr/Th; 5kHz Repetition Frequency	Pass
10	Surges for AC mains power ports	EN 55035:2017+A11:2020	1.2/50 μ s Tr/Td; 1kV Line to Line	Pass
11	Continuous induced RF disturbances for AC mains power ports (150kHz-80MHz)	EN 55035:2017+A11:2020	0,15 to 10MHz 3Vrms (emf), 10 to 30MHz 3V to 1Vrms(emf), 30 to 80MHz 1Vrms(emf), 80%,1kHz Amp. Mod.	Pass
12	Continuous induced RF disturbances for analogue/digital data ports (150kHz-80MHz)	EN 55035:2017+A11:2020	0,15 to 10MHz 3Vrms (emf), 10 to 30MHz 3V to 1Vrms(emf), 30 to 80MHz 1Vrms(emf), 80%,1kHz Amp. Mod.	Pass
13	Voltage dips and interruptions	EN 55035:2017+A11:2020	<5% residual voltage for 0.5 periods: B, 70% residual voltage: 25 periods for 50Hz, 30 periods for 60Hz: C, <5% residual voltage: 250 periods for 50Hz, 300 periods for 60Hz: C	Pass

Note: The highest internal frequency of the EUT is less than 108MHz, the measurement shall only be made up to 1 GHz.

TEST REPORT

Report No.: MTi250815018-0107E1

3 Test Facilities and accreditations

3.1 Test laboratory

Test laboratory:	Shenzhen Microtest Co., Ltd.
Test site location:	101, No.7, Zone 2, Xinxing Industrial Park, Fuhai Avenue, Xinhe Community, Fuhai Street, Bao'an District, Shenzhen, Guangdong, China
Telephone:	(86-755)88850135
Fax:	(86-755)88850136
CNAS Registration No.:	CNAS L5868
FCC Registration No.:	448573
IC Registration No.:	21760
CABID:	CN0093

TEST REPORT

Report No.: MTi250815018-0107E1

4 List of test equipment

No.	Equipment	Manufacturer	Model	Serial No.	Cal. date	Cal. Due
Conducted emissions from AC mains power ports (150kHz-30MHz)						
1	EMI Test Receiver	Rohde&schwarz	ESCI3	101368	2025-03-14	2026-03-13
2	Artificial mains network	Schwarzbeck	NSLK 8127	183	2025-03-18	2026-03-17
3	Artificial Mains Network	Rohde & Schwarz	ESH2-Z5	100263	2025-03-18	2026-03-17
Asymmetric mode conducted emissions (150kHz-30MHz)						
1	EMI Test Receiver	Rohde&schwarz	ESCI3	101368	2025-03-14	2026-03-13
2	8-wire Impedance Stabilization Network(ISN)	Schwarzbeck	NTFM 8158	199	2025-03-18	2026-03-17
Radiated emissions (30MHz-1GHz)						
1	EMI Test Receiver	Rohde&schwarz	ESCI7	101166	2025-03-14	2026-03-13
2	TRILOG Broadband Antenna	schwarabeck	VULB 9163	9163-1338	2025-05-23	2027-05-22
3	Amplifier	Hewlett-Packard	8447F	3113A06184	2025-03-18	2026-03-17
Voltage fluctuations and flicker						
1	Harmonics & Flicker Analyser	Laplace Instruments LTD	AC 2000A	311216	2025-03-14	2026-03-13
Electrostatic discharges						
1	Electrical Discharge Simulator	3CTEST	EDS 30V	ES031000420021	2025-05-06	2026-05-05
RF electromagnetic field disturbances						
1	Power Amplifier	micotop	MPA-80-1000-250	MPA1903081	2025-03-18	2026-03-17
2	Matrix Switch	micotop	MSW-80-6000-RS	MPA1903083	2025-03-19	2026-03-18
3	Power Amplifier	micotop	MPA-1000-6000-75	MPA1903082	2025-03-18	2026-03-17
4	Audio Analyzer	Agilent	U8903A	MY52140004	2025-03-18	2026-03-17
5	Stacked Log. Per. Broadband Antenna	Schwarzbeck	STLP 9129	00113	2023-04-26	2026-04-25
6	MXG RF Signal Generator	Agilent	N5181A	MY47420567	2025-03-18	2026-03-17
7	Power Sensor	Agilent	E9304A H18	MY41497225	2025-03-17	2026-03-16
8	Power Sensor	Agilent	E9304A H18	MY41499117	2025-03-17	2026-03-16
9	EPM Series Power Meter	Agilent	E4419B	MY45102877	2025-03-18	2026-03-17
Electrical fast transients / burst for AC mains power ports Electrical fast transients / burst for analogue/digital data ports						

TEST REPORT

Report No.: MTi250815018-0107E1

No.	Equipment	Manufacturer	Model	Serial No.	Cal. date	Cal. Due
1	Electrical Fast Transient Generator	HTEC Instrument Ltd.	HEFT 51	153701	2025-03-13	2026-03-12
Surges for AC mains power ports						
1	Surge Generator	HTEC Instrument Ltd.	HCWG 51	153702	2025-03-13	2026-03-12
Continuous induced RF disturbances for AC mains power ports (150kHz-80MHz) Continuous induced RF disturbances for analogue/digital data ports (150kHz-80MHz)						
1	Coupled Decoupling Network	Schloder	M2+M3-16A	A2210332/2015	2025-03-18	2026-03-17
Voltage dips and interruptions						
1	Cycle Sag Simulator	Prima	DRP61011AG	PR15056303	2025-03-13	2026-03-12

TEST REPORT

Report No.: MTi250815018-0107E1

5 Evaluation Results (Evaluation)

5.1 Harmonic current emission

Test Requirement:	Class A
Test Limit:	Not specified
Test Method:	EN IEC 61000-3-2:2019+A1:2021

5.1.1 Conclusion:

Refer to EN IEC 61000-3-2 clause 7.1:

"For the following categories of equipment, limits are not specified in this document:

- lighting equipment with a rated power less than but not equal to 5 W;
- equipment with a rated power of 75 W or less, other than lighting equipment;"

Since the rated power of the EUT is less than above described, it is deemed to comply with the requirement.

TEST REPORT

Report No.: MTi250815018-0107E1

6 Emission Test Results (EMI)

6.1 Conducted emissions from AC mains power ports (150kHz-30MHz)

Test Requirement:	Class B		
Test Limit:	Frequency Range	Limit (Quasi-Peak)	Limit (Average)
	0.15MHz to 0.5MHz	66dB(μV) to 56dB(μV)	56dB(μV) to 46dB(μV)
	0.5MHz to 5MHz	56dB(μV)	46dB(μV)
	5MHz to 30MHz	60dB(μV)	50dB(μV)
	Detector:	Peak for pre-scan (9kHz resolution bandwidth) 0.15M to 30MHz	
Test Method:	Clause 7 of CISPR 16-2-1:2014/AMD1:2017		
Procedure:	An initial pre-scan was performed with peak detector. Quasi-Peak or Average measurement were performed at the frequencies with maximized peak emission were detected. Remark: Level= Read Level+ Cable Loss+ LISN Factor		

6.1.1 E.U.T. Operation:

Operating Environment:					
Temperature:	25.3 °C	Humidity:	61 %	Atmospheric Pressure:	100 kPa
Pre test mode:	Mode1				
Final test mode:	Mode1				

6.1.2 Test Setup Diagram:

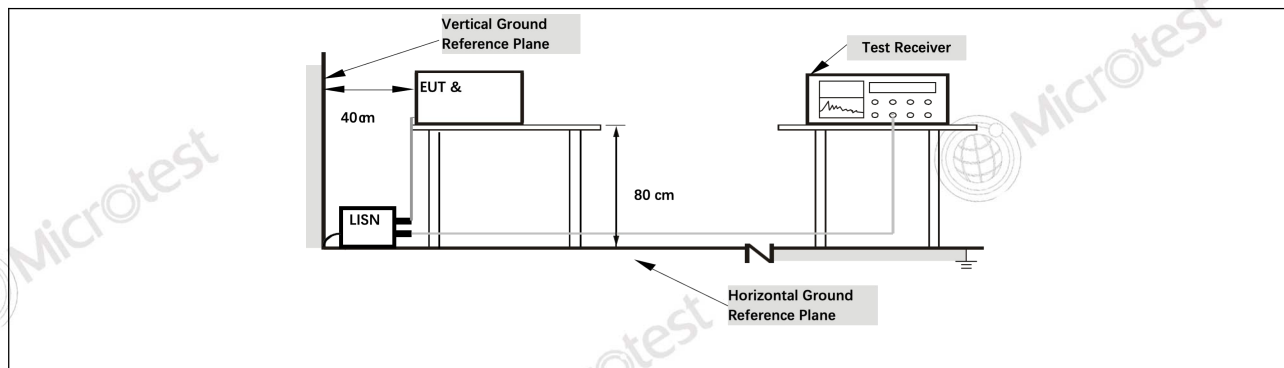

TEST REPORT

Report No.: MTi250815018-0107E1

6.1.3 Test Data:

Mode1 / Line: Line

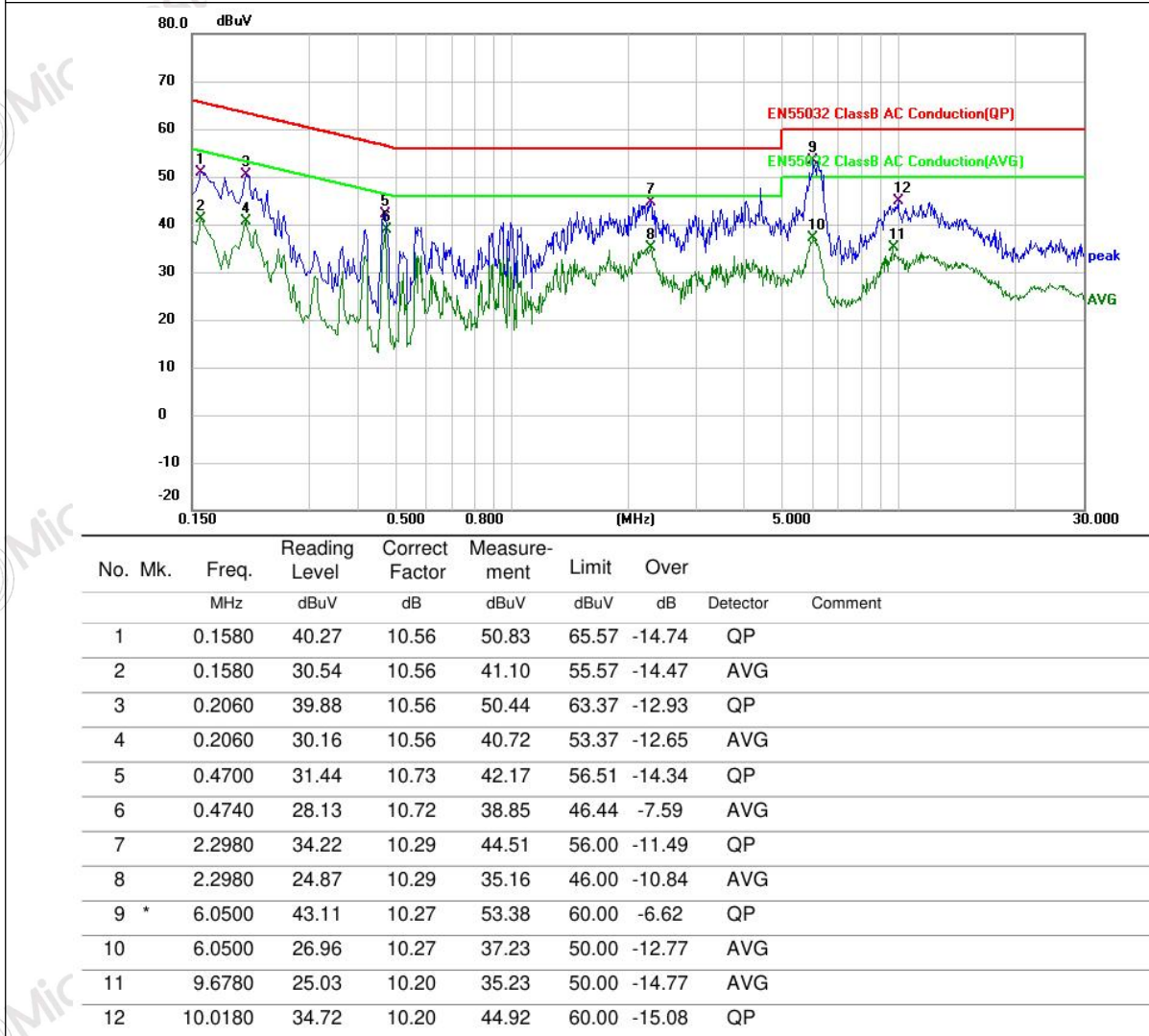

TEST REPORT

Report No.: MTi250815018-0107E1

Mode1 / Line: Neutral

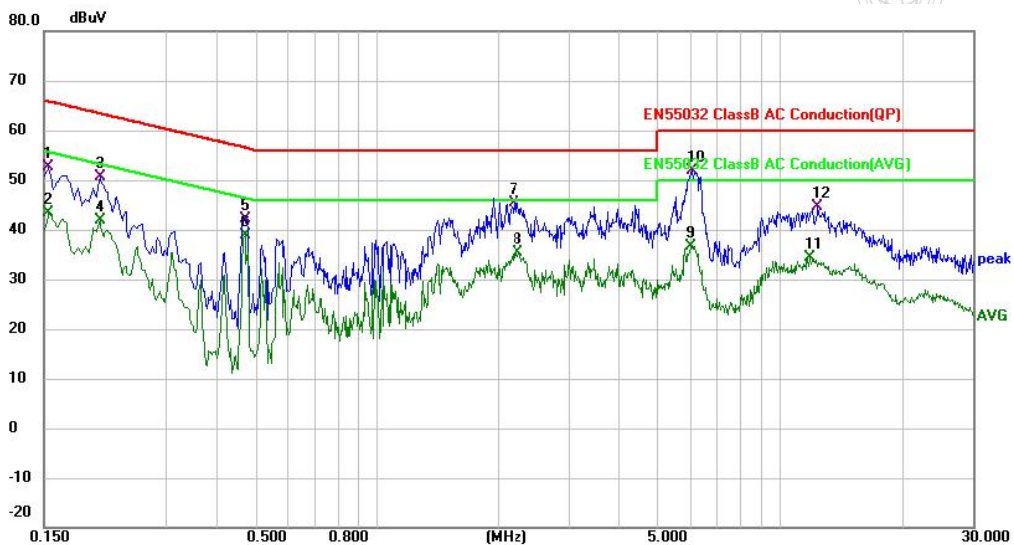

No.	Mk.	Freq. MHz	Reading Level dBuV	Correct Factor dB	Measure- ment dBuV	Limit dBuV	Over dB	Detector	Comment
1		0.1539	42.20	10.37	52.57	65.79	-13.22	QP	
2		0.1539	33.07	10.37	43.44	55.79	-12.35	AVG	
3		0.2060	40.22	10.44	50.66	63.37	-12.71	QP	
4		0.2060	31.38	10.44	41.82	53.37	-11.55	AVG	
5		0.4700	31.70	10.48	42.18	56.51	-14.33	QP	
6	*	0.4700	28.50	10.48	38.98	46.51	-7.53	AVG	
7		2.1900	35.06	10.44	45.50	56.00	-10.50	QP	
8		2.2260	24.90	10.44	35.34	46.00	-10.66	AVG	
9		6.0300	26.47	10.24	36.71	50.00	-13.29	AVG	
10		6.0739	41.64	10.24	51.88	60.00	-8.12	QP	
11		11.8300	23.99	10.30	34.29	50.00	-15.71	AVG	
12		12.4100	34.42	10.31	44.73	60.00	-15.27	QP	

TEST REPORT

Report No.: MTi250815018-0107E1

6.2 Asymmetric mode conducted emissions (150kHz-30MHz)

Test Requirement:	Class B		
Test Limit:	ISN:		
	Frequency Range	Limit (Quasi-Peak)	Limit (Average)
	0.15MHz to 0.5MHz	84dB(μV) to 74dB(μV)	74dB(μV) to 64dB(μV)
	0.5MHz to 30MHz	74dB(μV)	64dB(μV)
	Detector:	Peak for pre-scan (9kHz resolution bandwidth) 0.15M to 30MHz	
Test Method:	Clause 7 of CISPR 16-2-1:2014/AMD1:2017		
Procedure:	An initial pre-scan was performed with peak detector. Quasi-Peak or Average measurement were performed at the frequencies with maximized peak emission were detected. Remark: Level= Read Level+ Cable Loss+ LISN Factor		

6.2.1 E.U.T. Operation:

Operating Environment:					
Temperature:	25.5 °C	Humidity:	59 %	Atmospheric Pressure:	101 kPa
Pre test mode:	Mode1				
Final test mode:	Mode1				

6.2.2 Test Setup Diagram:

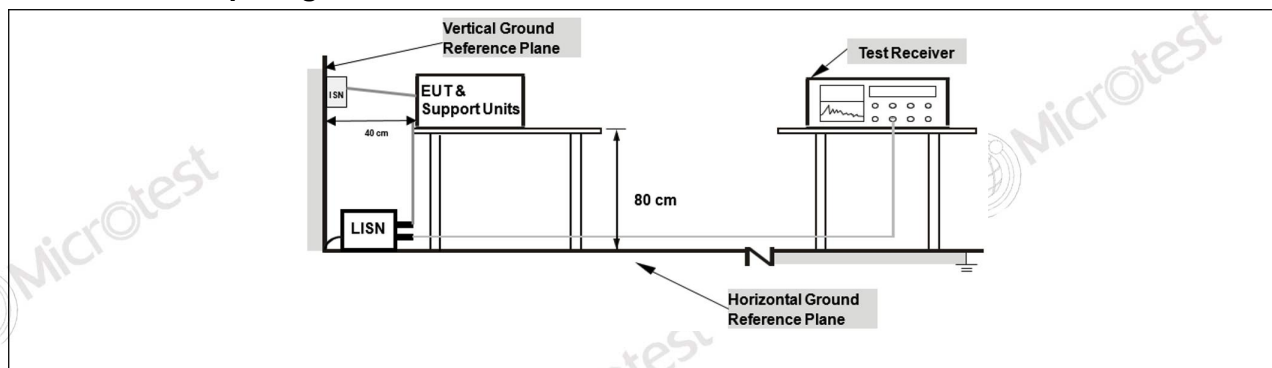

TEST REPORT

Report No.: MTi250815018-0107E1

6.2.3 Test Data:

Mode1

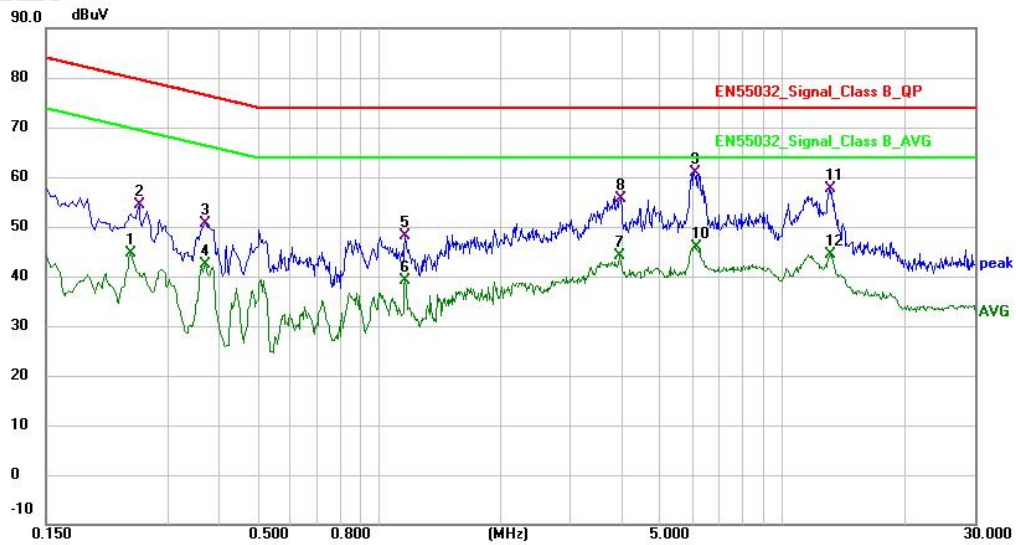

No.	Mk.	Freq. MHz	Reading Level dBuV	Correct Factor dB	Measure- ment dBuV	Limit dBuV	Over dB	Detector	Comment
1		0.2420	33.67	10.87	44.54	70.03	-25.49	AVG	
2		0.2540	43.55	10.82	54.37	79.63	-25.26	QP	
3		0.3700	40.00	10.57	50.57	76.50	-25.93	QP	
4		0.3700	31.80	10.57	42.37	66.50	-24.13	AVG	
5		1.1620	37.97	10.24	48.21	74.00	-25.79	QP	
6		1.1620	29.01	10.24	39.25	64.00	-24.75	AVG	
7		3.9780	33.94	10.24	44.18	64.00	-19.82	AVG	
8		3.9940	45.42	10.24	55.66	74.00	-18.34	QP	
9	*	6.0820	50.67	10.19	60.86	74.00	-13.14	QP	
10		6.0940	35.62	10.19	45.81	64.00	-18.19	AVG	
11		13.1140	47.44	10.21	57.65	74.00	-16.35	QP	
12		13.1820	34.13	10.21	44.34	64.00	-19.66	AVG	

TEST REPORT

Report No.: MTi250815018-0107E1

6.3 Radiated emissions (30MHz-1GHz)

Test Requirement:	Class B		
Test Limit:	Frequency (MHz)	Limit [dB(uV/m) at 10m]	Limit [dB(uV/m) at 3m]
	30 to 230	30	40
	230 to 1000	37	47
	Detector:	Peak for pre-scan (120kHz resolution bandwidth) 30M to 1000MHz	
Test Method:	Clause 7.3 of CISPR 16-2-3:2016		
Procedure:	An initial pre-scan was performed in the chamber using the spectrum analyser in peak detection mode. Quasi-peak measurements were conducted based on the peak sweep graph. The EUT was measured by BiConiLog antenna with 2 orthogonal polarities. Remark: Level= Read Level+ Cable Loss+ Antenna Factor- Preamp Factor		

6.3.1 E.U.T. Operation:

Operating Environment:					
Temperature:	24 °C	Humidity:	57 %	Atmospheric Pressure:	101 kPa
Pre test mode:	Mode1				
Final test mode:	Mode1				

6.3.2 Test Setup Diagram:

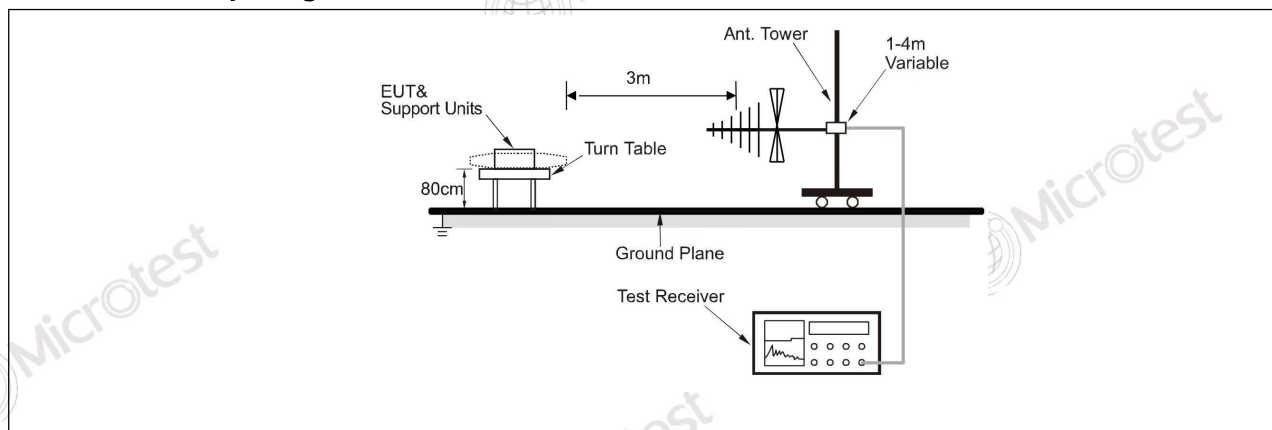

TEST REPORT

Report No.: MTi250815018-0107E1

6.3.3 Test Data:

Mode1 / Polarization: Horizontal



No.	Mk.	Freq. MHz	Reading Level dBuV	Correct Factor dB	Measure- ment dBuV/m	Limit dBuV/m	Over dB	Detector	Comment
1		43.8119	34.47	-7.56	26.91	40.00	-13.09	QP	
2		107.8877	40.92	-7.28	33.64	40.00	-6.36	QP	
3		180.0165	42.65	-9.99	32.66	40.00	-7.34	QP	
4	*	207.1226	44.44	-8.24	36.20	40.00	-3.80	QP	
5	!	399.0302	46.97	-5.15	41.82	47.00	-5.18	QP	
6		815.9678	38.84	0.28	39.12	47.00	-7.88	QP	

TEST REPORT

Report No.: MTI250815018-0107E1

Mode1 / Polarization: Vertical



No.	Mk.	Freq. MHz	Reading Level dBuV	Correct Factor dB	Measure- ment dBuV/m	Limit dBuV/m	Over dB	Detector	Comment
1	!	31.3992	47.62	-10.64	36.98	40.00	-3.02	QP	
2	*	45.2166	44.40	-7.40	37.00	40.00	-3.00	QP	
3	!	102.0013	43.15	-7.95	35.20	40.00	-4.80	QP	
4		140.3420	40.90	-9.79	31.11	40.00	-8.89	QP	
5	!	208.5801	44.74	-8.49	36.25	40.00	-3.75	QP	
6		407.5144	42.56	-5.03	37.53	47.00	-9.47	QP	

TEST REPORT

Report No.: MTi250815018-0107E1

6.4 Voltage fluctuations and flicker

Test Requirement:	Clause 4
Test Limit:	EN 61000-3-3, Clause 5
Test Method:	EN 61000-3-3:2013+A2:2021

6.4.1 E.U.T. Operation:

Operating Environment:					
Temperature:	25.6 °C	Humidity:	51 %	Atmospheric Pressure:	101 kPa
Pre test mode:	Mode1				
Final test mode:	Mode1				

6.4.2 Test Setup Diagram:

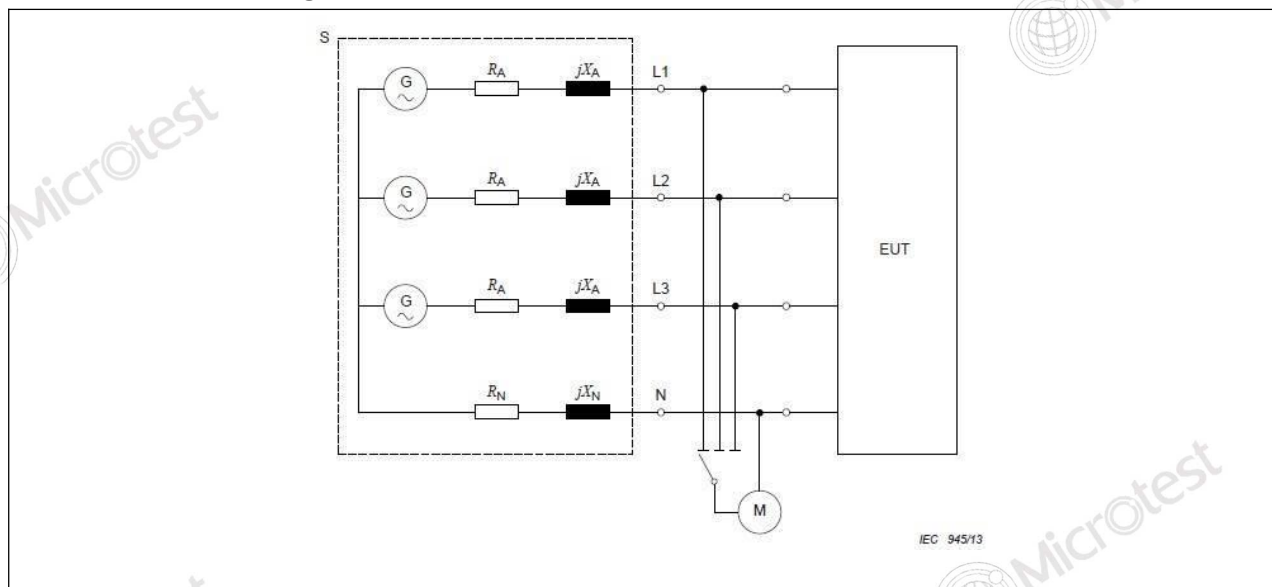

TEST REPORT

Report No.: MTi250815018-0107E1

6.4.3 Test Data:

HA-PC Link Plus. Software v4.00. Firmware v4.02
Tested On : 21 September 2025 21:17 for 600 Seconds.
Tested by : Dana

Load Power : 25.2 W 63.1 VA Power Factor 0.399
Load Current : 0.1 to 0.4 Arms 1.9 Apk Crest Factor 4.435

EN 61000-3-3:2013 - Voltage reduction is positive

Voltage Variations

Nominal Voltage: 230 Vrms
Highest Half-cycle level: +0.62%
Lowest Half-cycle level: +0.69%

d(max): 0.00% Limit: 4% PASS
t(max): 0.00seconds Limit: 500ms PASS

Steady State definition: >1000ms within +/- 0.2%
Largest d(c) change down: +0.12%
Largest d(c) change up: -0.00%
Largest d(c) change: +0.12% Limit: 3.3% PASS

Flicker

Short Term Flicker Pst: 0.00 Limit: 1.00 PASS

Pst Classifier Plt Calculation

Duration Flicker Interval Pst

0.1%	0.00
0.7%	0.00
1.0%	0.00
1.5%	0.00
2.2%	0.00
3%	0.00
4%	0.00
6%	0.00
8%	0.00
10%	0.00
13%	0.00
17%	0.00
30%	0.00
50%	0.00
80%	0.00

TEST REPORT

Report No.: MTi250815018-0107E1

7 Immunity Test Results (EMS)

General Performance Criteria

Performance Criteria A

The equipment shall continue to operate as intended without operator intervention. No degradation of performance, loss of function or change of operating state is allowed below a performance level specified by the manufacturer when the equipment is used as intended. The performance level may be replaced by a permissible loss of performance. If the minimum performance level or the permissible performance loss is not specified by the manufacturer, then either of these may be derived from the product description and documentation, and by what the user may reasonably expect from the equipment if used as intended.

Performance Criteria B

During the application of the disturbance, degradation of performance is allowed. However, no unintended change of actual operating state or stored data is allowed to persist after the test. After the test, the equipment shall continue to operate as intended without operator intervention; no degradation of performance or loss of function is allowed, below a performance level specified by the manufacturer, when the equipment is used as intended. The performance level may be replaced by a permissible loss of performance. If the minimum performance level (or the permissible performance loss), or recovery time, is not specified by the manufacturer, then either of these may be derived from the product description and documentation, and by what the user may reasonably expect from the equipment if used as intended.

Performance Criteria C

Loss of function is allowed, provided the function is self-recoverable, or can be restored by the operation of the controls by the user in accordance with the manufacturer's instructions. A reboot or re-start operation is allowed. Information stored in non-volatile memory, or protected by a battery backup, shall not be lost.

TEST REPORT

Report No.: MTi250815018-0107E1

7.1 Electrostatic discharges

Test Requirement:	Contact Discharge: +/- 4kV Air Discharge: +/- 8kV
Test Method:	EN 61000-4-2: 2009
Procedure:	Discharge Impedance: 330Ω/150pF Number of Discharge: Minimum 10 times at each test point Discharge Mode: Single Discharge Discharge Period: 1 second minimum
Performance Criteria:	B

7.1.1 E.U.T. Operation:

Operating Environment:					
Temperature:	25.6 °C	Humidity:	51 %	Atmospheric Pressure:	101 kPa
Pre test mode:	Mode1				
Final test mode:	Mode1				

7.1.2 Test Setup Diagram:

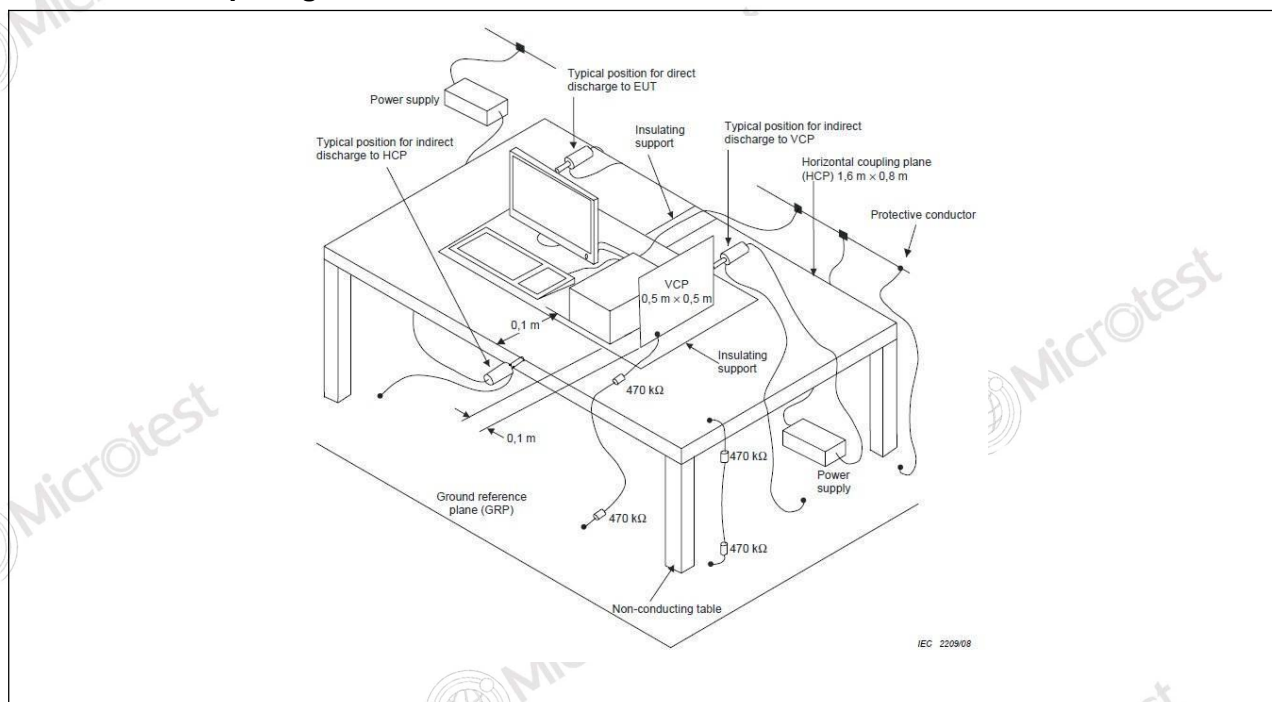

TEST REPORT

Report No.: MTi250815018-0107E1

7.1.3 Test Data:

Discharge type	Volt (kV)	Polarity	Test Point	Result/ Observations
Air discharge	2,4,8	+	1	B
Air discharge	2,4,8	-	1	B
Contact discharge	4	+	2	B
Contact discharge	4	-	2	B
Horizontal Coupling	4	+	3	A
Horizontal Coupling	4	-	3	A
Vertical Coupling	4	+	3	A
Vertical Coupling	4	-	3	A

Test Point: 1. All insulated enclosure and seams.

2. All accessible metal parts of the enclosure.

3. All side.

A: No degradation in the performance of the EUT was observed.

B: The EUT stopped operation during the test, but it can be recovered automatically after test.

The photos for discharge points of EUT

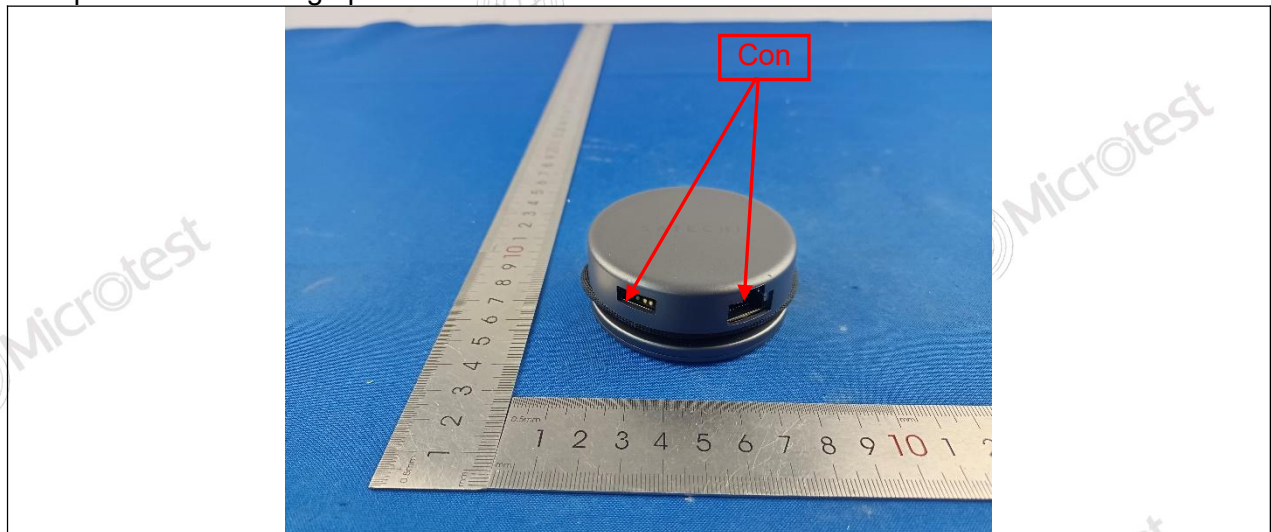

TEST REPORT

Report No.: MTi250815018-0107E1

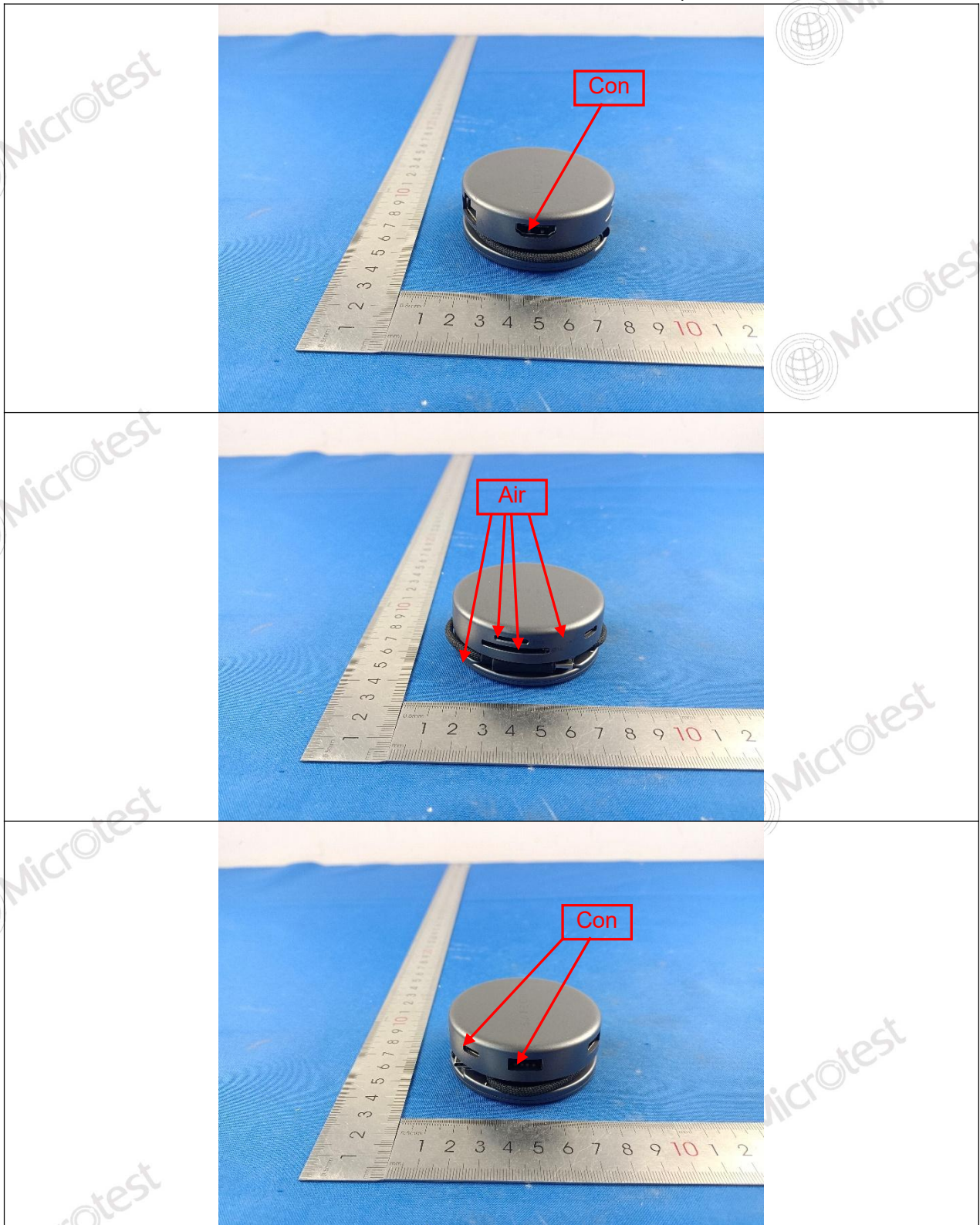

TEST REPORT

Report No.: MTi250815018-0107E1

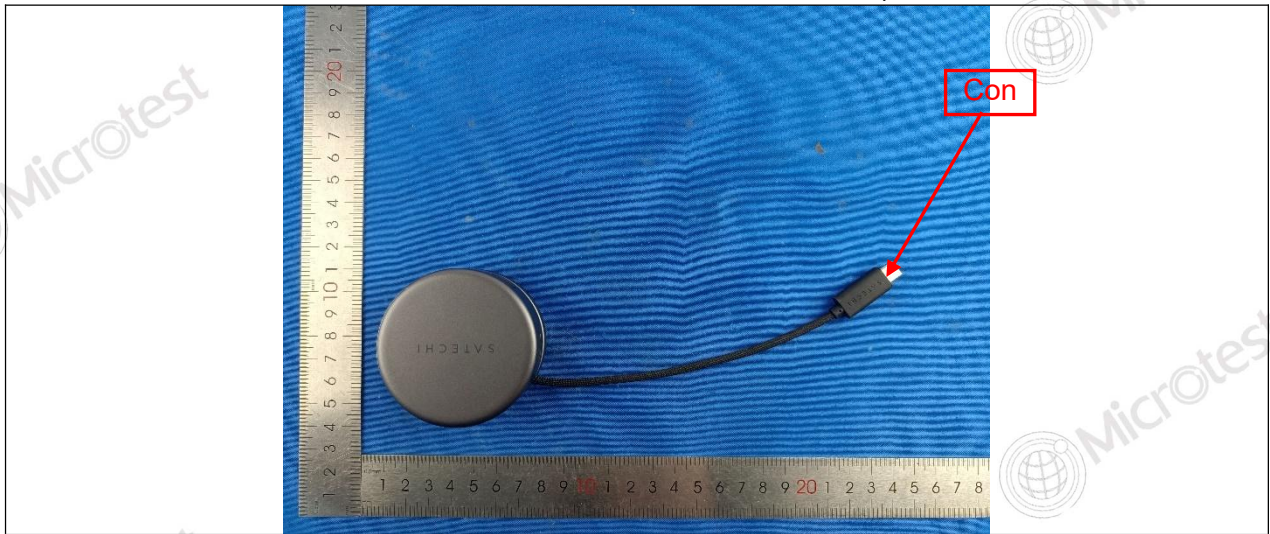

Note: Air is air discharge and Con is contact discharge.

TEST REPORT

Report No.: MTi250815018-0107E1

7.2 RF electromagnetic field disturbances

Test Requirement:	3V/m, 80%, 1kHz Amp. Mod.
Test Method:	EN IEC 61000-4-3: 2020
Procedure:	Frequency Range: 80MHz to 1GHz, 1800MHz, 2600MHz, 3500MHz, 5000MHz Antenna Polarisation: Vertical and Horizontal Modulation: 1kHz,80% Amp. Mod,1% increment
Performance Criteria:	A

7.2.1 E.U.T. Operation:

Operating Environment:					
Temperature:	25.6 °C	Humidity:	51 %	Atmospheric Pressure:	101 kPa
Pre test mode:	Mode1				
Final test mode:	Mode1				

7.2.2 Test Setup Diagram:

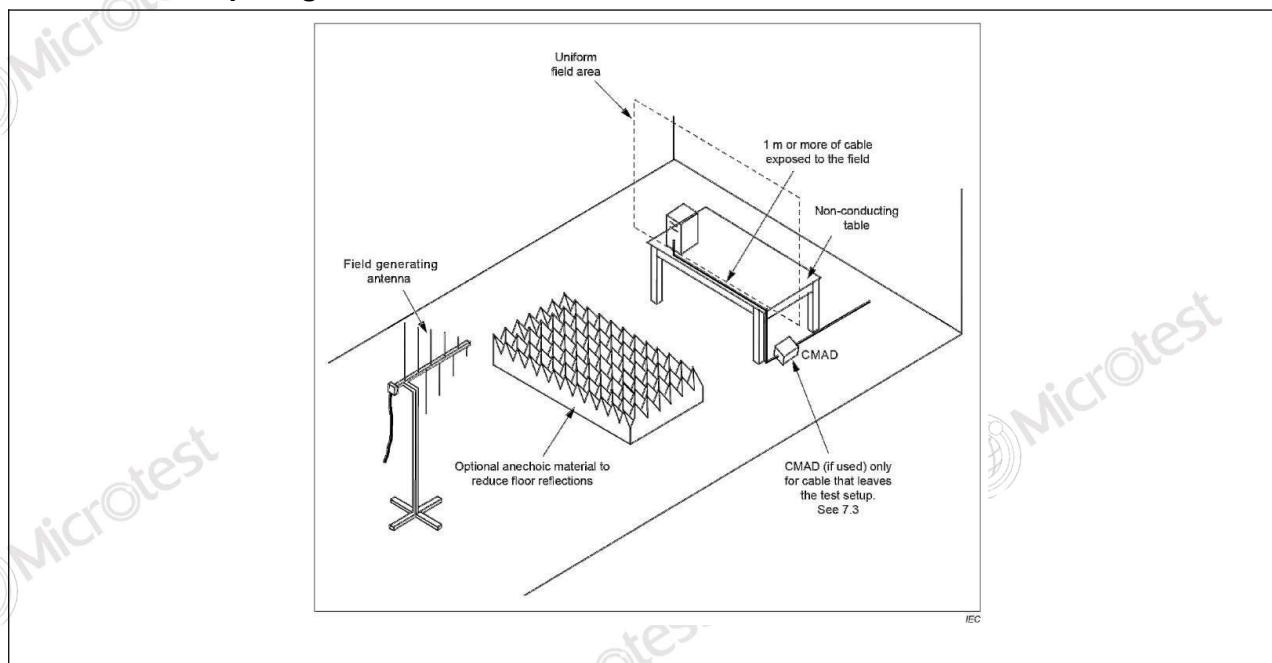

TEST REPORT

Report No.: MTi250815018-0107E1

7.2.3 Test Data:

Frequency	Field Strength (V/m)	EUT face	Dwell time	Result/ Observations
80MHz-1GHz	3	Front	3s	A
80MHz-1GHz	3	Back	3s	A
80MHz-1GHz	3	Left	3s	A
80MHz-1GHz	3	Right	3s	A
80MHz-1GHz	3	Top	3s	A
80MHz-1GHz	3	Bottom	3s	A
1800MHz	3	Front	3s	A
1800MHz	3	Back	3s	A
1800MHz	3	Left	3s	A
1800MHz	3	Right	3s	A
1800MHz	3	Top	3s	A
1800MHz	3	Bottom	3s	A
2600MHz	3	Front	3s	A
2600MHz	3	Back	3s	A
2600MHz	3	Left	3s	A
2600MHz	3	Right	3s	A
2600MHz	3	Top	3s	A
2600MHz	3	Bottom	3s	A
3500MHz	3	Front	3s	A
3500MHz	3	Back	3s	A
3500MHz	3	Left	3s	A
3500MHz	3	Right	3s	A
3500MHz	3	Top	3s	A
3500MHz	3	Bottom	3s	A
5000MHz	3	Front	3s	A
5000MHz	3	Back	3s	A
5000MHz	3	Left	3s	A
5000MHz	3	Right	3s	A
5000MHz	3	Top	3s	A
5000MHz	3	Bottom	3s	A

A: No degradation in the performance of the EUT was observed.

TEST REPORT

Report No.: MTi250815018-0107E1

7.3 Electrical fast transients / burst for AC mains power ports

Test Requirement:	1kV; 5/50ns Tr/Th; 5kHz Repetition Frequency
Test Method:	EN 61000-4-4: 2012
Procedure:	Repetition Frequency: 5kHz Burst Period: 300ms Test Duration: 2 minute per level & polarity
Performance Criteria:	B

7.3.1 E.U.T. Operation:

Operating Environment:					
Temperature:	25.6 °C	Humidity:	51 %	Atmospheric Pressure:	101 kPa
Pre test mode:	Mode1				
Final test mode:	Mode1				

7.3.2 Test Setup Diagram:

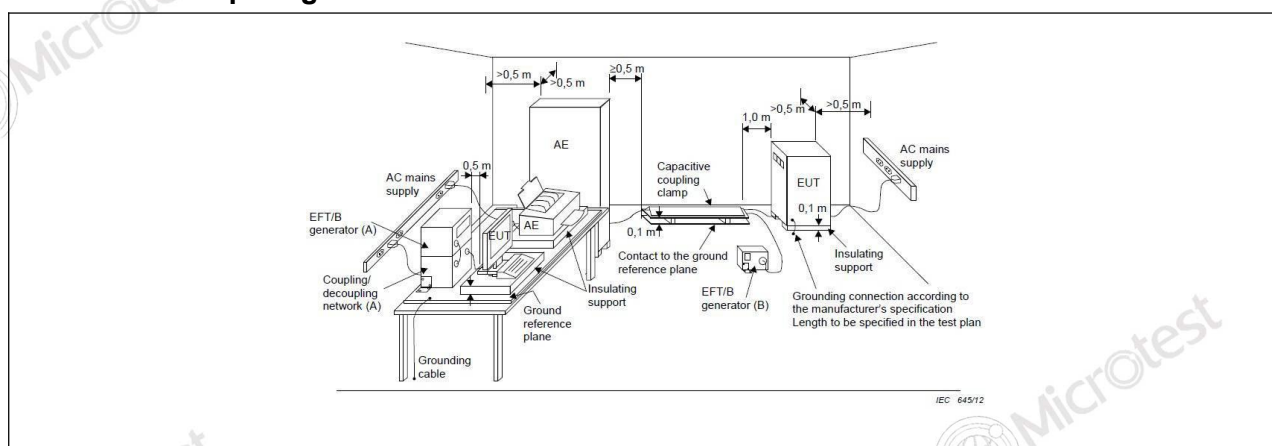

7.3.3 Test Data:

Port	Volt (kV)	Polarity	CDN/ Clamp	Result/ Observations
AC power port	1	+	CDN	A
AC power port	1	-	CDN	A

A: No degradation in the performance of the EUT was observed.

TEST REPORT

Report No.: MTi250815018-0107E1

7.4 Electrical fast transients / burst for analogue/digital data ports

Test Requirement:	0.5kV; 5/50ns Tr/Th; 5kHz Repetition Frequency
Test Method:	EN 61000-4-4: 2012
Procedure:	Repetition Frequency: 5kHz Burst Period: 300ms Test Duration: 2 minute per level & polarity
Performance Criteria:	B

7.4.1 E.U.T. Operation:

Operating Environment:					
Temperature:	25.6 °C	Humidity:	51 %	Atmospheric Pressure:	101 kPa
Pre test mode:	Mode1				
Final test mode:	Mode1				

7.4.2 Test Setup Diagram:

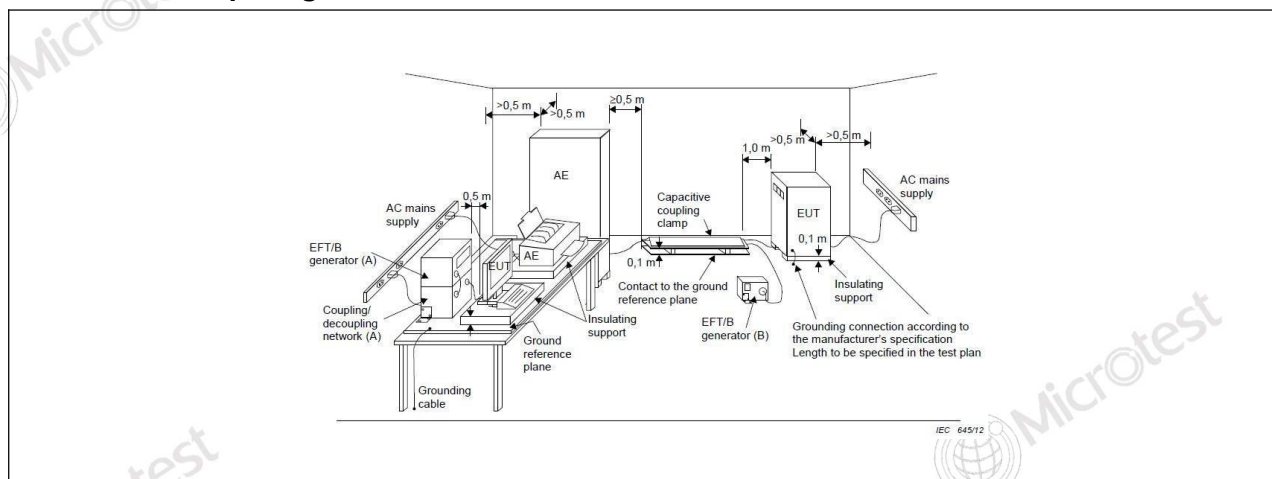

7.4.3 Test Data:

Port	Volt (kV)	Polarity	CDN/ Clamp	Result/ Observations
Signal port	0.5	+	Clamp	A
Signal port	0.5	-	Clamp	A

A: No degradation in the performance of the EUT was observed.

TEST REPORT

Report No.: MTi250815018-0107E1

7.5 Surges for AC mains power ports

Test Requirement:	1.2/50 μ s Tr/Td; 1kV Line to Line
Test Method:	EN 61000-4-5: 2014 +A1: 2017
Procedure:	Interval: 60s between each surge No. of surges: 5 positive, 5 negative at 90°, 270°
Performance Criteria:	B

7.5.1 E.U.T. Operation:

Operating Environment:					
Temperature:	25.6 °C	Humidity:	51 %	Atmospheric Pressure:	101 kPa
Pre test mode:	Mode1				
Final test mode:	Mode1				

7.5.2 Test Setup Diagram:

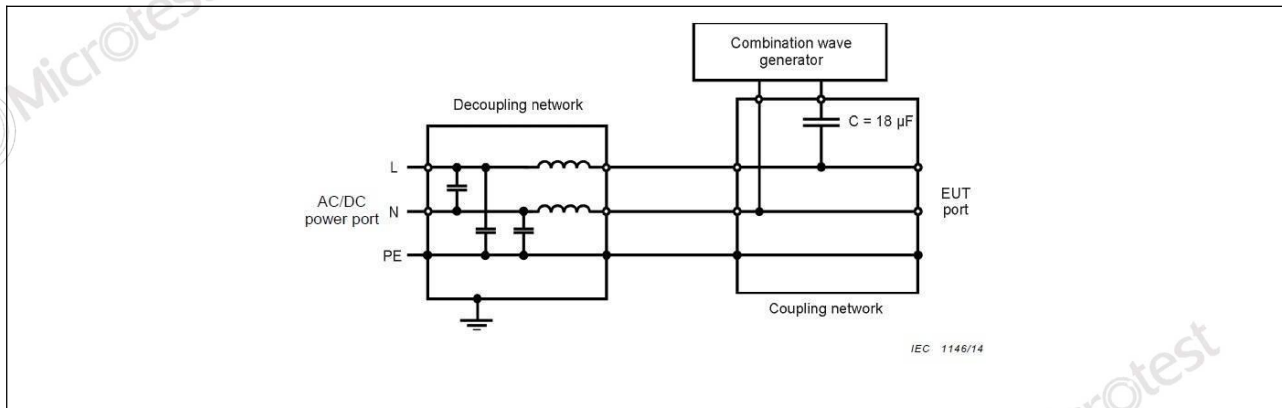

7.5.3 Test Data:

Port	Volt (kV)	Polarity	Phase(degree)	Result/Observations
L-N	1	+	90°	A
L-N	1	-	270°	A

A: No degradation in the performance of the EUT was observed.

TEST REPORT

Report No.: MTi250815018-0107E1

7.6 Continuous induced RF disturbances for AC mains power ports (150kHz-80MHz)

Test Requirement:	0,15 to 10MHz 3Vrms (emf), 10 to 30MHz 3V to 1Vrms(emf), 30 to 80MHz 1Vrms(emf), 80%,1kHz Amp. Mod.
Test Method:	EN 61000-4-6: 2014
Procedure:	Frequency Range: 0.15MHz to 80MHz Modulation: 80%, 1kHz Amplitude Modulation Step Size: 1%
Performance Criteria:	A

7.6.1 E.U.T. Operation:

Operating Environment:					
Temperature:	25.6 °C	Humidity:	51 %	Atmospheric Pressure:	101 kPa
Pre test mode:	Mode1				
Final test mode:	Mode1				

7.6.2 Test Setup Diagram:

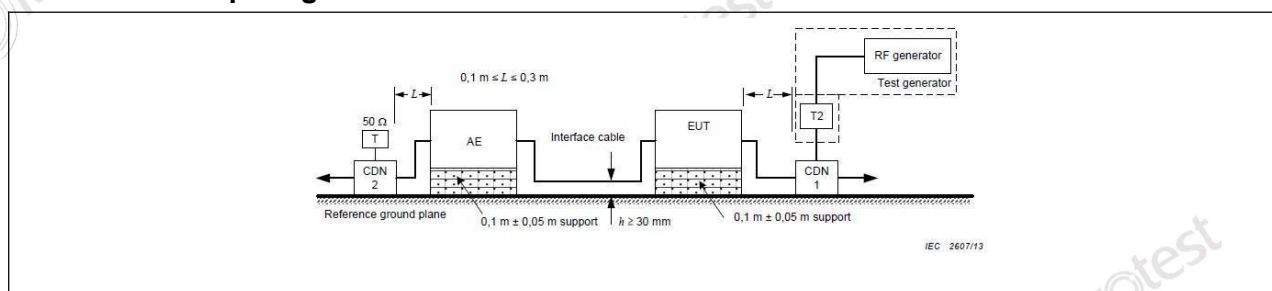

7.6.3 Test Data:

Port	Strength (Vrms)	CDN/Clamp	Dwell time	Result/Observations
AC power port	3(0.15MHz-10MHz)	CDN	3s	A
AC power port	3 to 1(10MHz-30MHz, Lines)	CDN	3s	A
AC power port	1(30MHz-80MHz)	CDN	3s	A

A: No degradation in the performance of the EUT was observed.

TEST REPORT

Report No.: MTi250815018-0107E1

7.7 Continuous induced RF disturbances for analogue/digital data ports (150kHz-80MHz)

Test Requirement:	0,15 to 10MHz 3Vrms (emf), 10 to 30MHz 3V to 1Vrms(emf), 30 to 80MHz 1Vrms(emf), 80%,1kHz Amp. Mod.
Test Method:	EN 61000-4-6: 2014
Procedure:	Frequency Range: 0.15MHz to 80MHz Modulation: 80%, 1kHz Amplitude Modulation Step Size: 1%
Performance Criteria:	A

7.7.1 E.U.T. Operation:

Operating Environment:					
Temperature:	25.6 °C	Humidity:	51 %	Atmospheric Pressure:	101 kPa
Pre test mode:	Mode1				
Final test mode:	Mode1				

7.7.2 Test Setup Diagram:

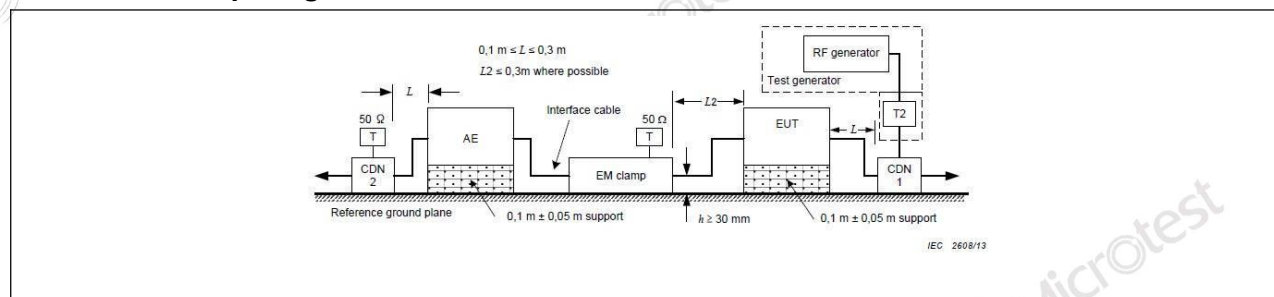

7.7.3 Test Data:

Port	Strength (Vrms)	CDN/ Clamp	Dwell time	Result/ Observations
Signal port	3(0.15MHz-10MHz)	Clamp	3s	A
Signal port	3 to 1(10MHz-30MHz, Lines)	Clamp	3s	A
Signal port	1(30MHz-80MHz)	Clamp	3s	A

A: No degradation in the performance of the EUT was observed.

TEST REPORT

Report No.: MTi250815018-0107E1

7.8 Voltage dips and interruptions

Test Requirement:	<5% residual voltage for 0.5 periods 70% residual voltage: 25 periods for 50Hz, 30 periods for 60Hz <5% residual voltage: 250 periods for 50Hz, 300 periods for 60Hz
Test Method:	EN IEC 61000-4-11:2020
Procedure:	<5% residual voltage for 0.5 period 70% residual voltage: 25 periods for 50Hz, 30 periods for 60Hz <5% residual voltage: 250 periods for 50Hz, 300 periods for 60Hz No. of Dips / Interruptions: 3 per Level Time between dropout: 10s
Performance Criteria:	B, C, C

7.8.1 E.U.T. Operation:

Operating Environment:					
Temperature:	25.6 °C	Humidity:	51 %	Atmospheric Pressure:	101 kPa
Pre test mode:	Mode1				
Final test mode:	Mode1				

7.8.2 Test Setup Diagram:

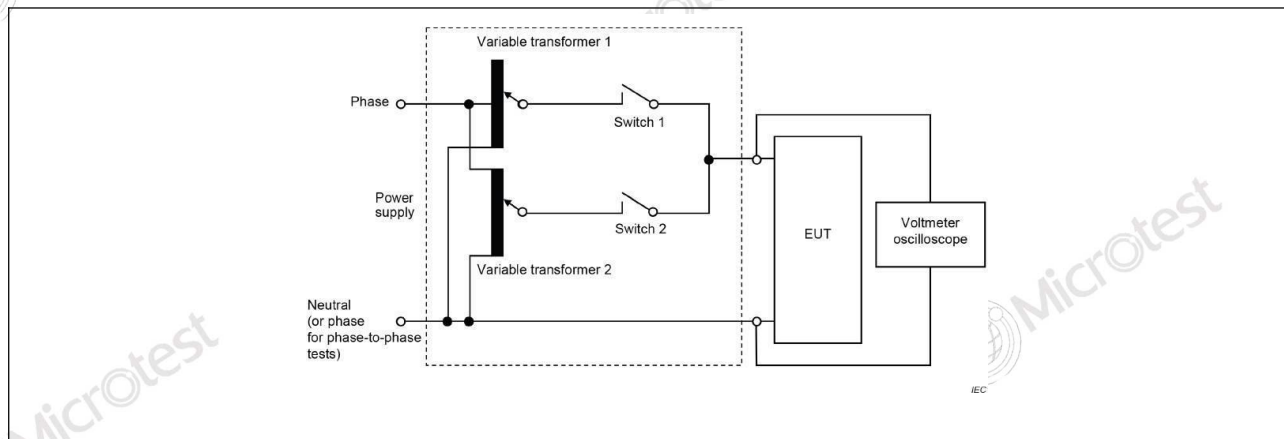

7.8.3 Test Data:

Level %UT	Phase (degree)	Duration	No. of Dips/ Interruptions	Result/ Observations
0	0°	0.5 Cycles	3	A
0	0°	250 Cycles	3	B
70	0°	25 Cycles	3	A

A: No degradation in the performance of the EUT was observed.

B: The EUT stopped operation during the test, but it can be recovered automatically after test.

TEST REPORT

Report No.: MTi250815018-0107E1

Photographs of the test setup

Conducted emissions from AC mains power ports (150kHz-30MHz)



Asymmetric mode conducted emissions (150kHz-30MHz)

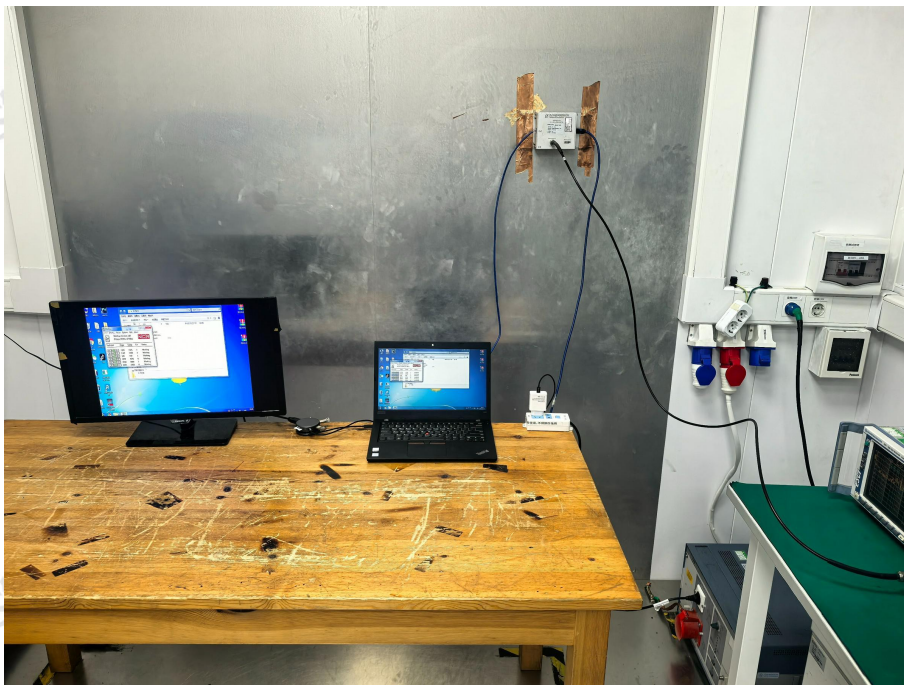

TEST REPORT

Report No.: MTi250815018-0107E1

Radiated emissions (30MHz-1GHz)

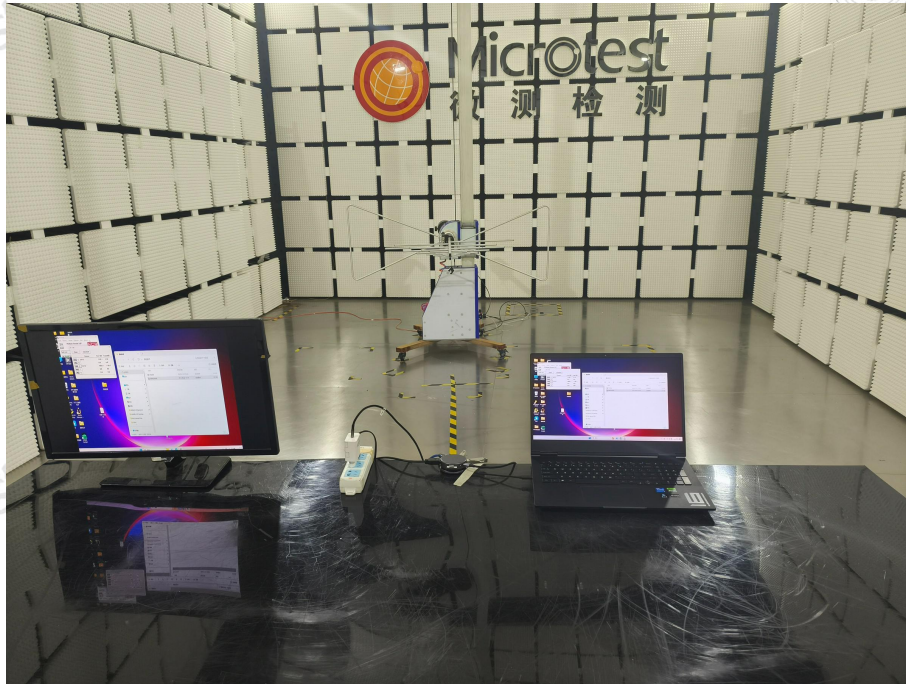

Voltage fluctuations and flicker



TEST REPORT

Report No.: MTi250815018-0107E1

Electrostatic discharges



RF electromagnetic field disturbances



TEST REPORT

Report No.: MTi250815018-0107E1

Electrical fast transients / burst for AC mains power ports



Electrical fast transients / burst for analogue/digital data ports



TEST REPORT

Report No.: MTi250815018-0107E1

Surges for AC mains power ports



Continuous induced RF disturbances for AC mains power ports (150kHz-80MHz)



TEST REPORT

Report No.: MTi250815018-0107E1

Continuous induced RF disturbances for analogue/digital data ports (150kHz-80MHz)



Voltage dips and interruptions



TEST REPORT

Report No.: MTi250815018-0107E1

Photographs of the EUT

Refer to Appendix - EUT Photos

TEST REPORT

Report No.: MTi250815018-0107E1

Statement

1. This report is invalid without the seal and signature of the laboratory.
2. The test results of this report are only responsible for the samples submitted. Client shall be responsible for representativeness of the sample and authenticity of the material.
3. The report shall not be partially reproduced without the written consent of the Laboratory.
4. This report is invalid if transferred, altered or tampered with in any form without authorization.
5. The observations or tests with special mark fall outside the scope of accreditation, and are only used for purpose of commission, research, training, internal quality control etc.
6. Any objection to this report shall be submitted to the laboratory within 15 days from the date of receipt of the report.

***** END OF REPORT *****